

Hidrolik Silindir (Cetop)

Hydraulic Cylinder (Cetop)

Silindirler / Cylinders

MAG®



(CETOP R58H STANDARDI)
(R58H Standard)

NHS ... - ... - ... - ... - ...

Silindir Çapı Ø Piston Diameter Ø	Standart Stroklar Standard Strokes mm	Bağlantı Şekilleri / Mountings			
50		ÖFB	Ön Flanş Bağlantı / Front flange mounting	RH	Piston Mili Sertleştirilmiş ve Krom Kaplı Hardened and chrome plated piston rod
63	100	AFB	Arka Flanş Bağlantı / Rear flange mounting	RS	Piston Mili Paslanmaz Stainless steel piston rod
80	200	AEB	Arka Eklem Bağlantı / Rear swivel flange mounting		Ck 45 Krom Kaplı Ck 45 chrome plated piston rod
100	300	AEBK	Küresel Arka Eklem Bağlantı Rear swivel flange mounting with spherical bearing		
125	400	ÖEB	Ön Eklem Bağlantı / Piston rod swivel mounting		
160	500	ÖEBK	Küresel Ön Eklem Bağlantı Piston rod swivel mounting with spherical bearing		Nitril Sızdırmazlık Elemanı NBR Seal
200		OEB	Orta Eklem Bağlantı / Central trunnion mounting	SV	Viton Sızdırmazlık Elemanı Viton Seal
		AB	Ayak Bağlantı / Foot mounting		

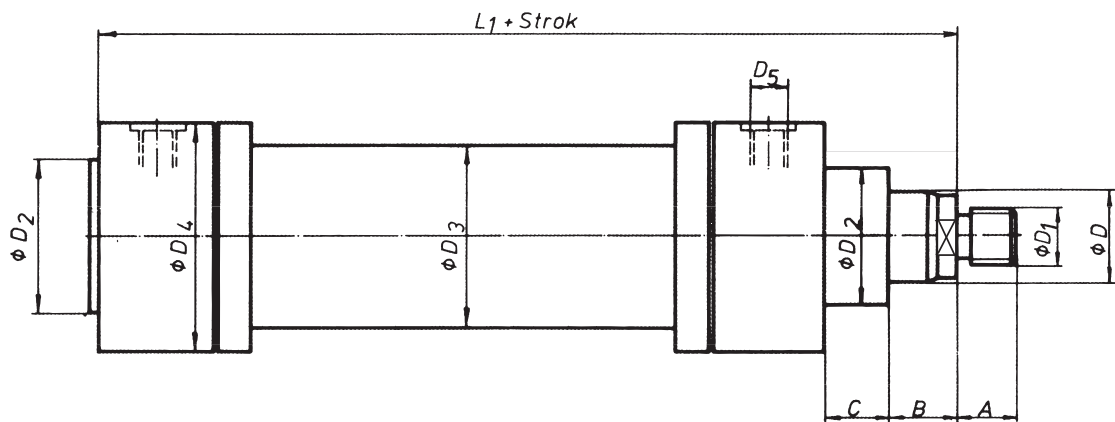

	A	B	C	ØD	D ₁	ØD ₂	ØD ₃	ØD ₄	D ₅	ØD ₆	ØD ₇
NHS - 50	28	14	24	28	M20X1,5	60	60	110	G 1/2"	11	126
NHS - 63	36	16	29	36	M27X2	70	75	125	G 3/4"	14	145
NHS - 80	45	18	36	45	M33X2	85	95	135	G 3/4"	18	165
NHS - 100	56	20	37	56	M42X2	106	115	160	G 1"	22	200
NHS - 125	63	23	37	70	M48X2	132	145	195	G 1"	22	235
NHS - 160	85	25	41	90	M64X3	160	180	250	G 1 1/4"	22	280
NHS - 200	95	30	45	110	M80X3	200	230	310	G 1 1/4"	26	340

	ØD ₈	ØD ₉	ØD ₁₀	E	F	G	H	L ₁	L ₂	L ₃	R	SW
NHS - 50	150	25	30	18	32	25	65	205	225	257	25	22
NHS - 63	175	32	38	20	40	32	80	224	249	289	35	30
NHS - 80	200	40	47	22	50	40	97	250	282	332	40	36
NHS - 100	240	50	58	25	63	50	120	300	332	395	50	46
NHS - 125	280	63	70	28	71	63	140	325	357	428	60	60
NHS - 160	330	80	90	30	90	80	180	370	406	505	80	75
NHS - 200	390	100	110	35	112	100	210	450	490	615	100	100

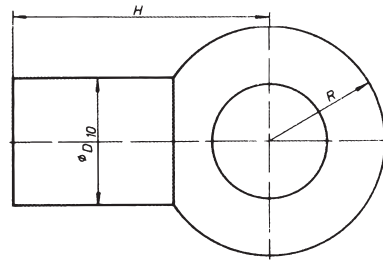
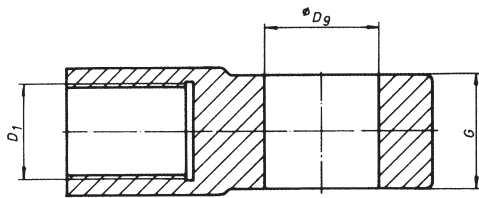
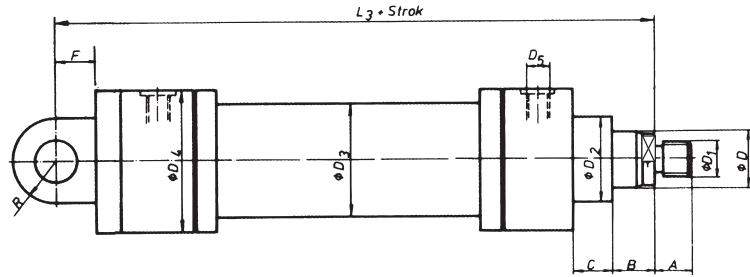
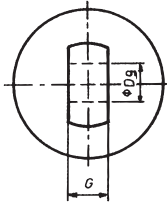
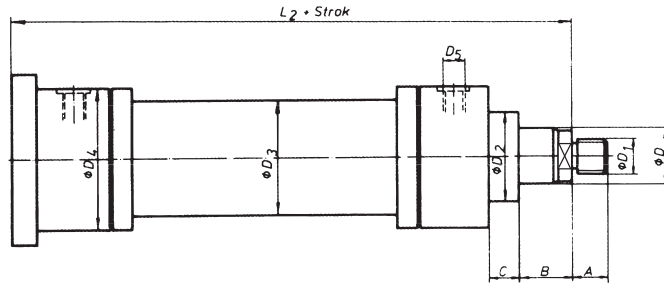
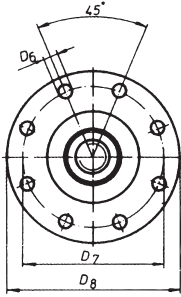
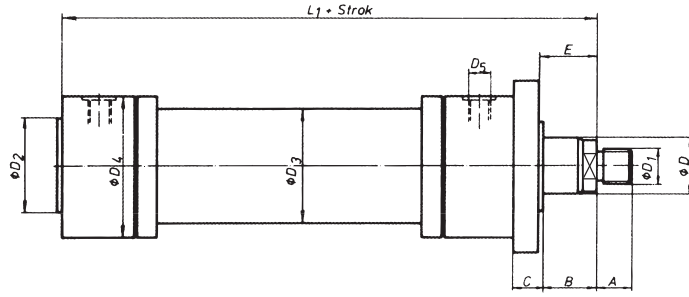
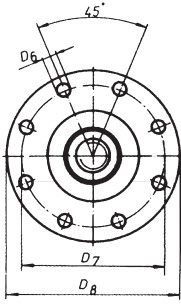

İtme kuvveti / Compression Force : (daN)

Basınç / Pressure (bar)

	20	40	60	80	100	120	140	160
NHS - 50	390	780	1170	1560	1950	2340	2730	3120
NHS - 63	620	1240	1860	2480	3100	3720	4340	4960
NHS - 80	1000	2000	3000	4000	5000	6000	7000	8000
NHS - 100	1550	3100	4650	6200	7750	9300	10850	12400
NHS - 125	2450	4900	7350	9800	11250	14700	17150	19600
NHS - 160	4000	8000	12000	16000	20000	24000	28000	32000
NHS - 200	6250	12500	18750	25000	31250	37500	43750	50000

TEKNİK ÖZELLİKLER / TECHNICAL SPECIFICATIONS

Çalışma Basıncı / Max. Operating Pressure	: 160 bar
Piston Hızı / Max. Piston Speed	: 0,5 m/s
Çalışma Sıcaklığı / Temperature Range	: -20°C to 80°C
Yağ / Oil Type	: Mineral Yağlar / Mineral Oils
Viskozite / Viscosity	: 5 c St - 300 c St

Piston kolu burkulma eğrisi
Piston rod buckling diagram

