

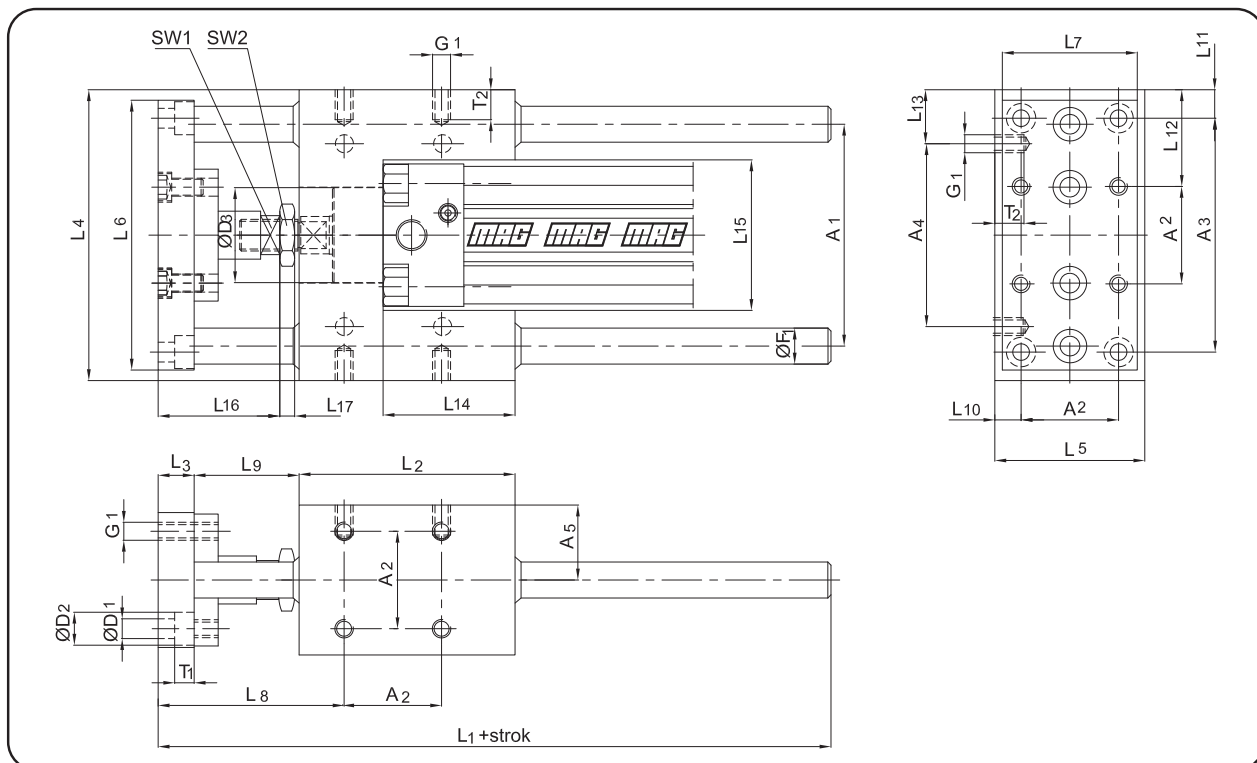

LN - . . . - . . .

<b>Montaj Yapılacak Piston Çapı</b> <i>Diameter Of The Cylinder To Be Mounted</i>
32, 40, 50, 63, 80, 100

<b>Standart Stroklar</b> <i>Standard Strokes</i>
50, 100, 160, 200, 300, 400, 500

# Ölçüler / Dimensions



	A1	A2	A3	A4	A5	D1	D2	D3	F1	G1	L1 + Strok	L2	L3	L4	L5	L6
LN - 32	74	32,5	78	61	25	6,6	11	30	12	M6	132	72	12	97	50	90
LN - 40	87	38	84	69	29	6,6	11	34	16	M6	149	84	12	115	58	110
LN - 50	104	46,5	100	85	35	9	15	40	20	M8	175	100	15	137	70	130
LN - 63	119	56,5	105	100	42,5	9	15	40	20	M8	190	115	15	152	85	145
LN - 80	148	72	130	130	52,5	11	18	48	25	M10	238	150	20	189	105	180
LN - 100	172	89	150	150	65	11	18	50	25	M10	254	165	20	215	130	200

	L7	L8	L9	L10	L11	L12	L13	L14	L15	L16	L17	SW1	SW2	T1	T2
LN - 32	45	57	30	8,75	9,5	32,25	18	44	50,2	38	6	13	17	6,5	10
LN - 40	54	66	39	10	15,5	38,5	23	51	58,2	45	6	15	19	6,5	10
LN - 50	63	75	45	11,75	18,5	45,25	26	60	70	53	7	22	24	9	13
LN - 63	80	75	45	14,25	23,5	47,75	26	75	85,2	53	7	22	24	9	13
LN - 80	100	109	69	16,5	29,5	58,5	29,5	114	102	68	9	27	30	11	16
LN - 100	120	118	73	20,5	32,5	63	32,5	128	132	68	9	27	30	11	16