

Pnömatik Yön Denetim Valfi

Pneumatic Directional Control Valve

Mekanik Uyarılı Valfler
Electrically Actuated Valves

MAG®

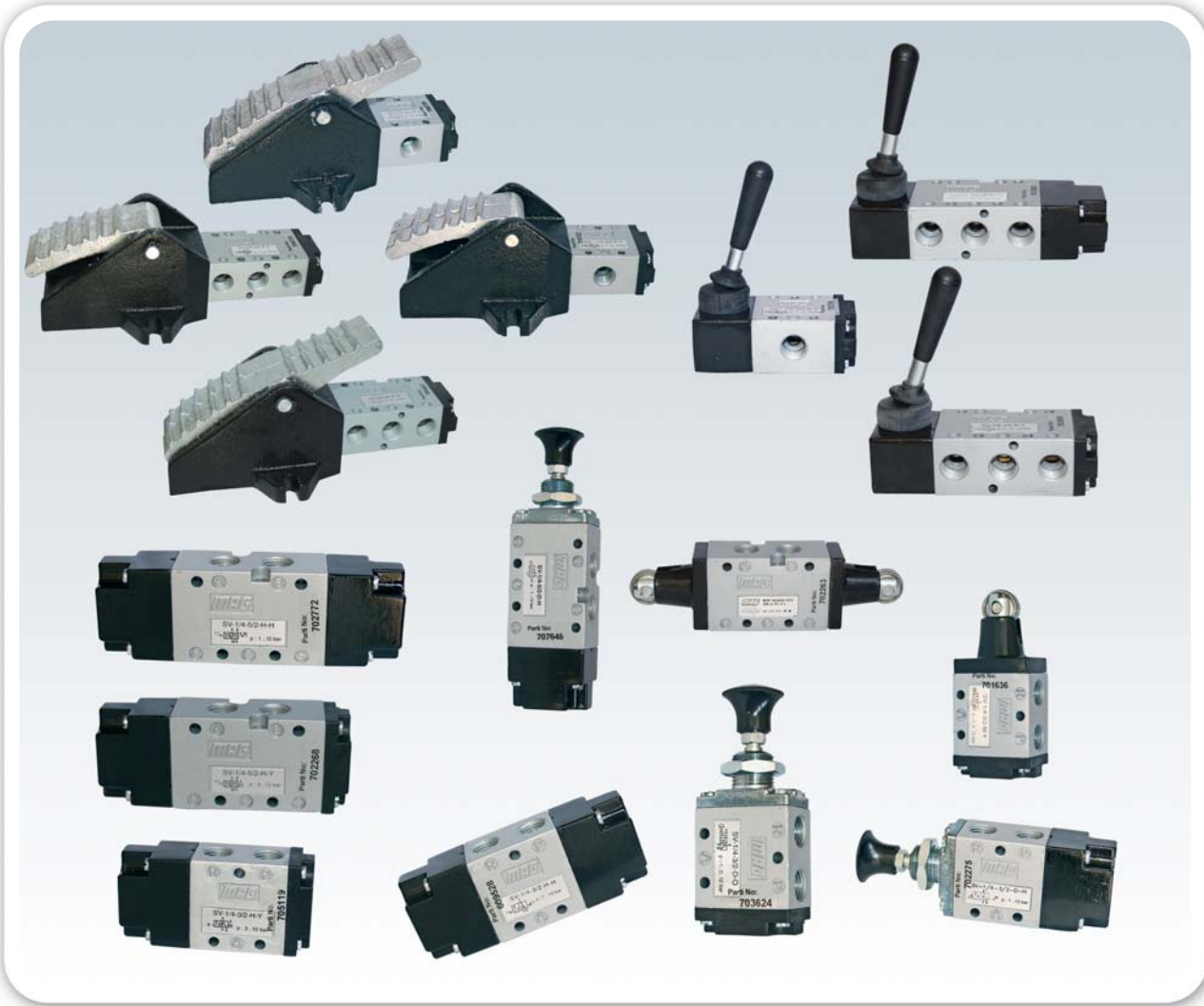

SV - 1/4 - . - . - . - . - .

Ölçü Connection
R 1/4"

Yol Sayısı Number of ways
3
5

Konum Sayısı Number of positions
2
3

Uyarı Şekli Actuation Type	
D	Düğme / Push button
H	Hava Uyarı Air impulse
K	Kaol / Lever
M	Makara / Cam
P	Pedal

Geri Geliş Şekli Return Actuation Type	
H	Hava Uyarı / Air impulse
Y	Yay / Mechanical spring
M	Yay / Cam
O	Uyarı Şekli Aynı Same as actuation type

SV-1/4-3/2

Hava Uyarılı Valf Air impulse operated valve

SV-1/4-3/2-H-H

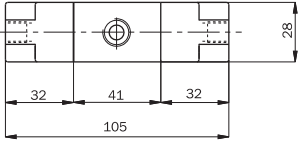

Simge / Symbol	Tip / Type	Çalışma Basıncı (bar) Operating Pressure Range (bar)	Ağırlık (g) Weight (g)
	SV-1/4-3/2-H-H	1....12	615
	SV-1/4-3/2-H-Y	3....12	435

SV-1/4-3/2-H-Y

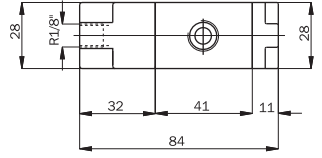

Kollu Valf Lever operated valve

SV-1/4-3/2-K-H

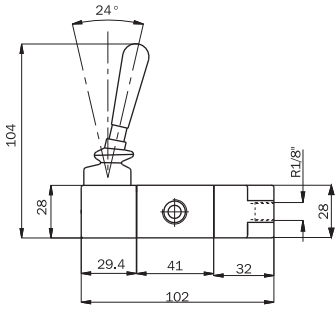

Simge / Symbol	Tip / Type	Çalışma Basıncı (bar) Operating Pressure Range (bar)	Ağırlık (g) Weight (g)
	SV-1/4-3/2-K-H	1....12	675
	SV-1/4-3/2-K-Y	-1...0...12	500
	SV-1/4-3/2-K-O	-1...0...12	560

SV-1/4-3/2-K-Y ve
SV-1/4-3/2-K-O

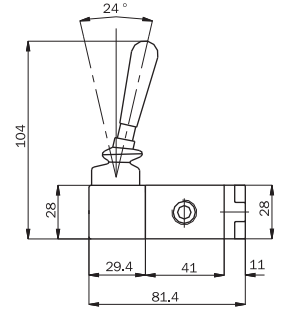

Makaralı Valf Cam operated valve

SV-1/4-3/2-M-H

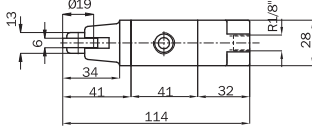

SV-1/4-3/2-M-M

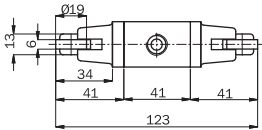

Simge / Symbol	Tip / Type	Çalışma Basıncı (bar) Operating Pressure Range (bar)	Ağırlık (g) Weight (g)
	SV-1/4-3/2-M-H	1...12	525
	SV-1/4-3/2-M-M	-1...0...12	425
	SV-1/4-3/2-M-Y	-1...0...12	365

SV-1/4-3/2-M-Y

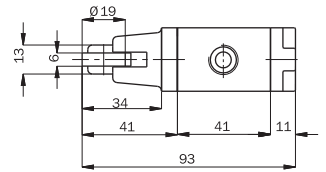

Pedallı Valf Pedal operated valve

SV-1/4-3/2-P-H

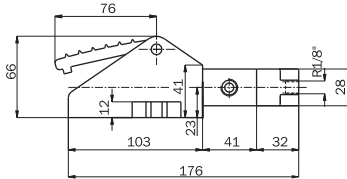

Simge / Symbol	Tip / Type	Çalışma Basıncı (bar) Operating Pressure Range (bar)	Ağırlık (g) Weight (g)
	SV-1/4-3/2-P-H	1....12	1720
	SV-1/4-3/2-P-Y	-1...0...12	1585
	SV-1/4-3/2-P-O	-1...0...12	1680

SV-1/4-3/2-P-Y

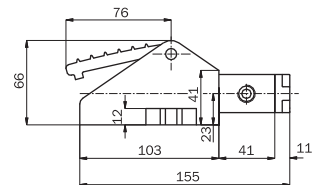

SV-1/4-3/2-P-O

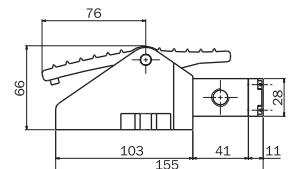

Düğmeli Valf

Push button operated valve

SV-1/4-3/2-D-O

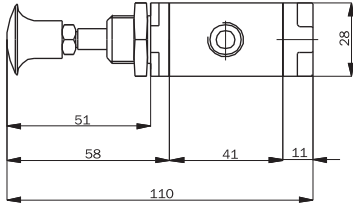

Simge / Symbol	Tip / Type	Çalışma Basıncı (bar) Operating Pressure Range (bar)	Ağırlık (g) Weight (g)
	SV-1/4-3/2-D-H	1....12	535
	SV-1/4-3/2-D-Y	-1..0..12	365
	SV-1/4-3/2-D-O	-1..0..12	360

SV-1/4-3/2-D-H

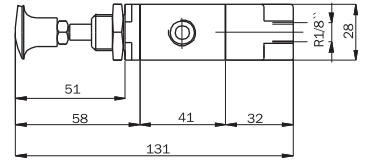

SV-1/4-3/2-D-Y

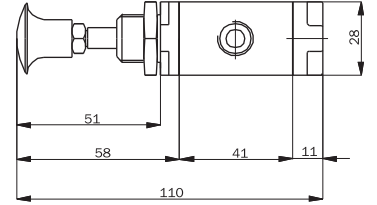

SV - 1/4 - 5/2

Düğmeli Valf

Push button operated valve

SV-1/4-5/2-D-O

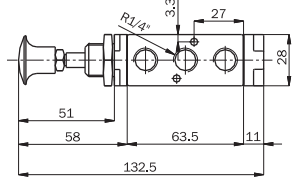

Simge / Symbol	Tip / Type	Çalışma Basıncı (bar) Operating Pressure Range (bar)	Ağırlık (g) Weight (g)
	SV-1/4-5/2-D-H	1....12	660
	SV-1/4-5/2-D-Y	-1..0..12	300
	SV-1/4-5/2-D-O	-1..0..12	300

SV-1/4-5/2-D-H

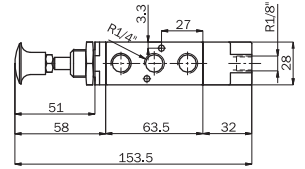

SV-1/4-5/2-D-Y

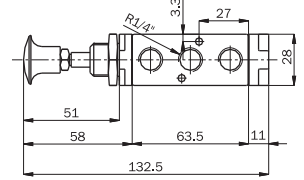

Hava Uyarılı Valf

Air impulse operated valve

SV-1/4-5/2-H-H

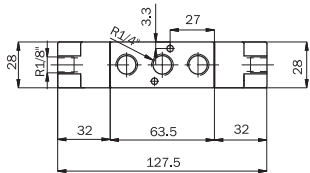

Simge / Symbol	Tip / Type	Çalışma Basıncı (bar) Operating Pressure Range (bar)	Ağırlık (g) Weight (g)
	SV-1/4-5/2-H-H	1....12	560
	SV-1/4-5/2-H-Y	3....12	390

SV-1/4-5/2-H-Y

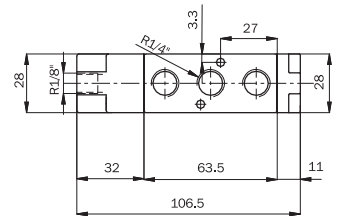

Kollu Valf

Lever operated valve

SV-1/4-5/2-K-H

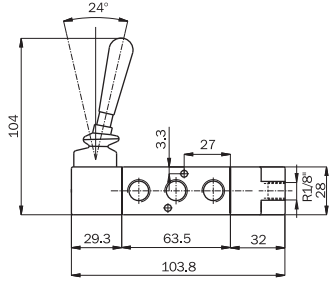

Simge / Symbol	Tip / Type	Çalışma Basıncı (bar) Operating Pressure Range (bar)	Ağırlık (g) Weight (g)
	SV-1/4-5/2-K-H	1...12	615
	SV-1/4-5/2-K-Y	-1...0...12	445
	SV-1/4-5/2-K-O	-1...0...12	445

SV-1/4-5/2-K-Y ve
SV-1/4-5/2-K-O

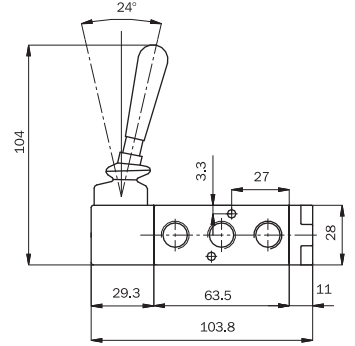

Makaralı Valf

Cam operated valve

SV-1/4-5/2-M-H

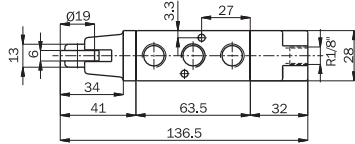

SV-1/4-5/2-M-M

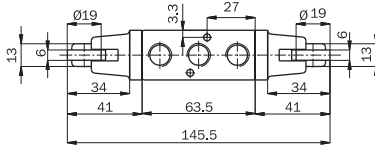

Simge / Symbol	Tip / Type	Çalışma Basıncı (bar) Operating Pressure Range (bar)	Ağırlık (g) Weight (g)
	SV-1/4-5/2-M-H	1...12	660
	SV-1/4-5/2-M-M	-1...0...12	560
	SV-1/4-5/2-M-Y	-1...0...12	305

SV-1/4-5/2-M-Y

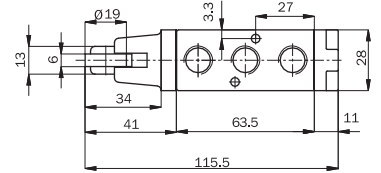

Pedallı Valf

Pedal operated valve

SV-1/4-5/2-P-H

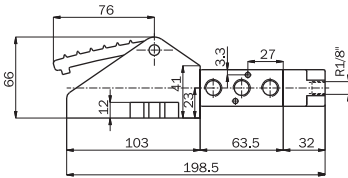

Simge / Symbol	Tip / Type	Çalışma Basıncı (bar) Operating Pressure Range (bar)	Ağırlık (g) Weight (g)
	SV-1/4-5/2-P-H	1...12	1835
	SV-1/4-5/2-P-Y	-1...0...12	1435
	SV-1/4-5/2-P-O	-1...0...12	1550

SV-1/4-5/2-P-Y

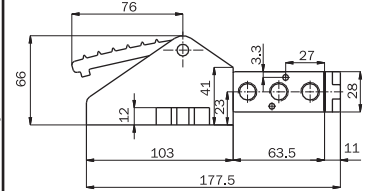

SV-1/4-5/2-P-O

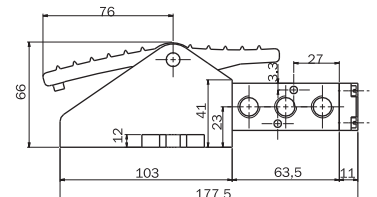

SV - 1/4 - 5/3

Düğmeli Valf

Push button operated valve

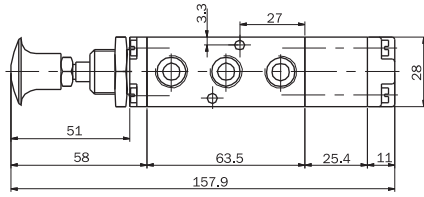

Simge / Symbol	Tip / Type	Çalışma Basıncı (bar) Operating Pressure Range (bar)	Ağırlık (g) Weight (g)
	SV-1/4-5/3-D-Y	-1..0..12	650

Hava Uyarılı Valf

Air impulse operated valve

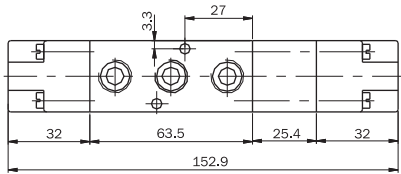

Simge / Symbol	Tip / Type	Çalışma Basıncı (bar) Operating Pressure Range (bar)	Ağırlık (g) Weight (g)
	SV-1/4-5/3-H-H	3.....12	840

Kollu Valf

Lever operated valve

SV-1/4-5/3-K-Y

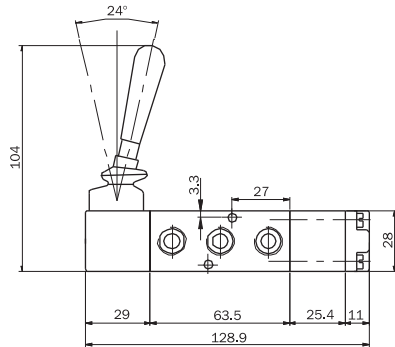

Simge / Symbol	Tip / Type	Çalışma Basıncı (bar) Operating Pressure Range (bar)	Ağırlık (g) Weight (g)
	SV-1/4-5/3-K-Y	-1..0..12	535
	SV-1/4-5/3-K-O	-1..0..12	440

SV-1/4-5/3-K-O

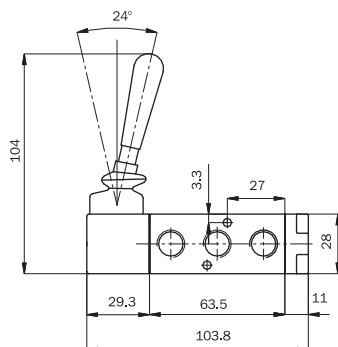

SV-1/4-3/2-.....

Gövdesi

Main Body Dimensions

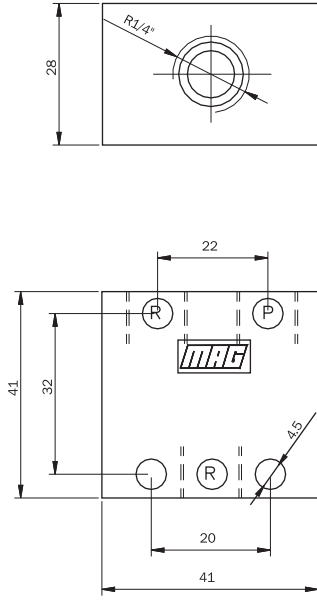

SV-1/4-5/2-.....

Gövdesi

Main Body Dimensions

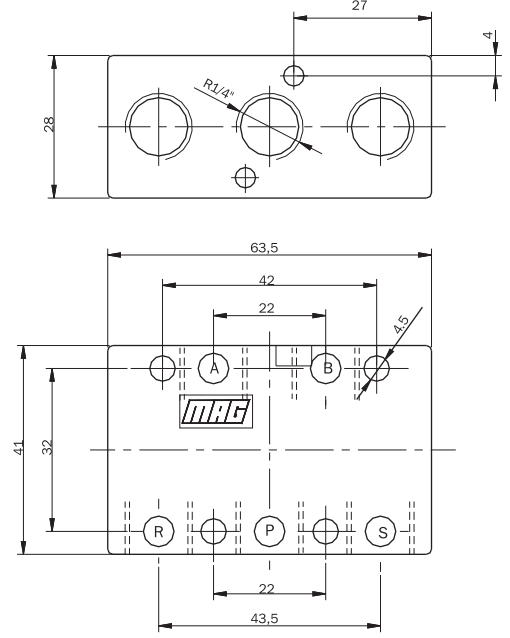

SV - 1/4 - ile elde edilen piston hızı eğrisi

Piston speed graph formed by using SV - 1/4

