

Toz keçelerinin standart üretimi NBR kauçuk olup, FKM olarak üretimi mümkündür. Toz keçeleri; sistemin içine dışarıdan yabancı maddelerin piston miline yapışarak sistemin içerisine girmesine engel olur.

ÖLÇÜ	d	D	H	h1+(0.2)	h2+(0.2)
010*018*8/6-4	10	18	8	6	4
012*020*8/6-4	12	20	8	6	4
014*022*8/6-4	14	22	8	6	4
015*023*8/6-4	15	23	8	6	4
018*026*8/6-4	18	26	8	6	4
020*028*8/6-4	20	28	8	6	4
022*030*8/6-4	22	30	8	6	4
024*032*8/6-4	24	32	8	6	4
025*033*8/6-4	24	33	8	6	4
028*036*8/6-4	28	36	8	6	4
030*038*8/6-4	30	38	8	6	4
032*040*8/6-4	32	40	8	6	4
035*043*8/6-4	35	43	8	6	4
036*044*8/6-4	36	44	8	6	4
037*045*8/6-4	37	45	8	6	4
038*046*8/6-4	38	46	8	6	4
040*048*8/6-4	40	48	8	6	4
042*050*8/6-4	42	50	8	6	4
045*053*8/6-4	45	53	8	6	4
046*054*8/6-4	46	54	8	6	4
048*056*8/6-4	48	56	8	6	4
050*058*8/6-4	50	58	8	6	4
052*060*8/6-4	52	60	8	6	4
055*063*8/6-4	55	63	8	6	4
056*064*8/6-4	56	64	8	6	4
060*068*8/6-4	60	68	8	6	4
063*071*8/6-4	63	71	8	6	4
065*073*8/6-4	65	73	8	6	4
068*076*8/6-4	68	76	8	6	4
070*078*8/6-4	70	78	8	6	4
075*083*8/6-4	75	83	8	6	4
080*088*8/6-4	80	88	8	6	4
085*093*8/6-4	85	93	8	6	4
090*098*8/6-4	90	98	8	6	4
095*103*8/6-4	95	103	8	6	4
100*108*8/6-4	100	108	8	6	4
105*117*11/8.2-5.5	105	117	11	8.2	5.5
110*122*11/8.2-5.5	110	122	11	8.2	5.5
115*127*11/8.2-5.5	115	127	11	8.2	5.5
120*132*11/8.2-5.5	120	132	11	8.2	5.5
125*137*11/8.2-5.5	125	137	11	8.2	5.5
130*142*11/8.2-5.5	130	142	11	8.2	5.5

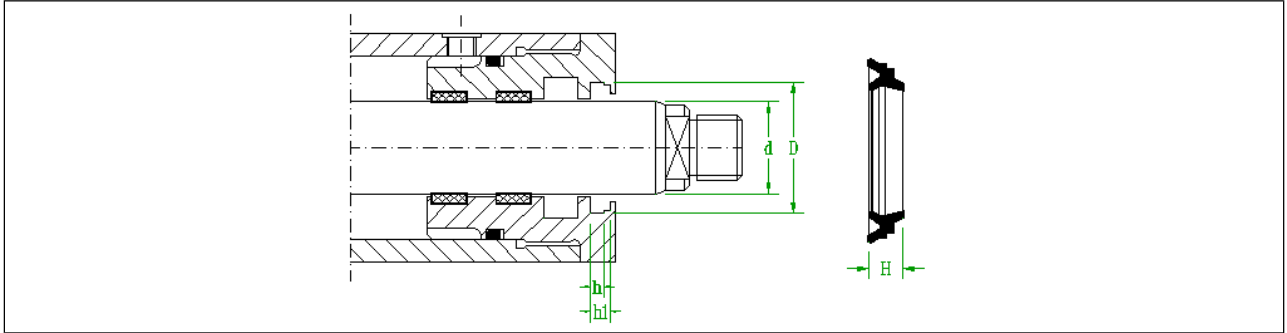

ÖLÇÜ	d	D	H	h1±(0,2)	h±(0,2)
135*147*11/8.2-5.5	135	147	11	8.2	5.5
140*152*11/8.2-5.5	140	152	11	8.2	5.5
145*157*11/8.2-5.5	145	157	11	8.2	5.5
150*162*11/8.2-5.5	150	162	11	8.2	5.5
155*167*11/8.2-5.5	155	167	11	8.2	5.5
160*172*11/8.2-5.5	160	172	11	8.2	5.5
165*177*11/8.2-5.5	165	177	11	8.2	5.5
170*182*11/8.2-5.5	170	182	11	8.2	5.5
180*192*11/8.2-5.5	180	192	11	8.2	5.5
185*197*11/8.2-5.5	185	197	11	8.2	5.5
190*202*11/8.2-5.5	190	202	11	8.2	5.5
195*207*11/8.2-5.5	195	207	11	8.2	5.5
200*212*11/8.2-5.5	200	212	11	8.2	5.5
205*220*13/9.5-6.4	205	220	13	9.5	6.4
220*235*13/9.5-6.4	220	235	13	9.5	6.4
225*240*13/9.5-6.4	225	240	13	9.5	6.4
240*255*13/9.5-6.4	240	255	13	9.5	6.4
250*265*13/9.5-6.4	250	265	13	9.5	6.4
260*275*13/9.5-6.4	260	275	13	9.5	6.4
275*290*13/9.5-6.4	275	290	13	9.5	6.4
280*295*13/9.5-6.4	280	295	13	9.5	6.4
290*305*13/9.5-6.4	290	305	13	9.5	6.4
300*315*13/9.5-6.4	300	315	13	9.5	6.4
320*335*13/9.5-6.4	320	335	13	9.5	6.4
350*365*13/9.5-6.4	350	365	13	9.5	6.4
360*375*13/9.5-6.4	360	375	13	9.5	6.4
370*385*13/9.5-6.4	370	385	13	9.5	6.4